

Installation Instructions

Road Defender Push Bumper Part # 5077A-2L71

2015 - 2017 Dodge Charger Pursuit

Do not attempt to install this product on any vehicle other than the one listed above!

Parts List				
Item	QTY	Code	Description	Max Torque
1	1 pc	5077A-2L	Push Bumper Body	
2	1 set	50770CB	Main bracket	
3	4 pcs	G507582	Spacer tube	
4	4 pcs		M8 x 90mm Hex bolt	16 Ft. Lbs.
5	4 pcs		5/16" Flat washer	
6	4 pcs		15/16" Lock washer	
7	1 pc		1/2" wire bolt guide	
8	8 pcs		3/8 x 1 1/4" hex bolt	30 Ft. Lbs.
9	16 pcs		3/8" Flat washer	
10	8 pcs		3/8" Lock washer	
11	8 pcs		3/8" Hex nut	30 Ft. Lbs.
12	2 pcs	LR71A0AA	Light mask	
13	2 pcs	LR51A0BA	Light mounting bracket	
14	2 pcs	50770NA	Lateral light support	
15	4 pcs		#6-32 x 3/4" Allen head bolt	
16	4 pcs		#6 Flat washer	
17	4 pcs		#6-32 Lock nut	
18	4 pcs		1/4 x 2" Allen Head Bolt	10 Ft. Lbs.
19	4 pcs		1/4 x 3/4" Allen Head Bolt	10 Ft. Lbs.
20	4 pcs		1/4" Lock Washer	

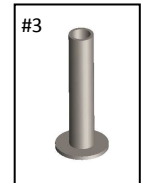
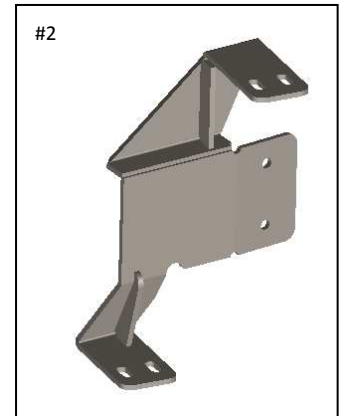

Tool Required:

5/32" Allen wrench
 7mm, 10mm, 13mm & 9/16" Sockets
 9/16" Wrench
 Phillips & Slotted Blade Screw Driver
 Ratchet & Ratchet Extension
 Pliers

Approximated installation time: 110 min.

Read the installation instructions completely and verify that all of the parts listed are accounted for. If you have defective, missing or damaged parts or need assistance, please contact Go Rhino Products for fast, friendly customer service at: 1-888-427-4466 or email: warranty@gorhino.com

To maintain and care this product keep it clean and do not use abrasive cleaners or polish waxes. It is recommended to use only non-abrasive automotive wax such as pure carnauba to avoid scratches and rust.

Light Bar Assembly

1. Place the light between the mask and the mounting bracket. **See image 1.**
2. Attach the light assembly using (1) #6 x 3/4" button allen bolt, (1) #6 flat washer and (1) #6 hex lock nut per side. **Image 2 & 3.**

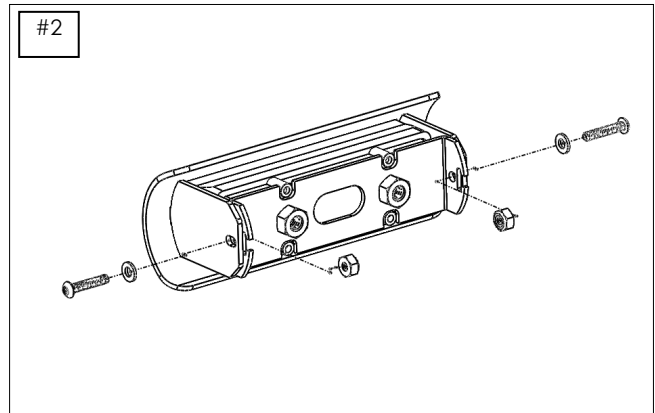
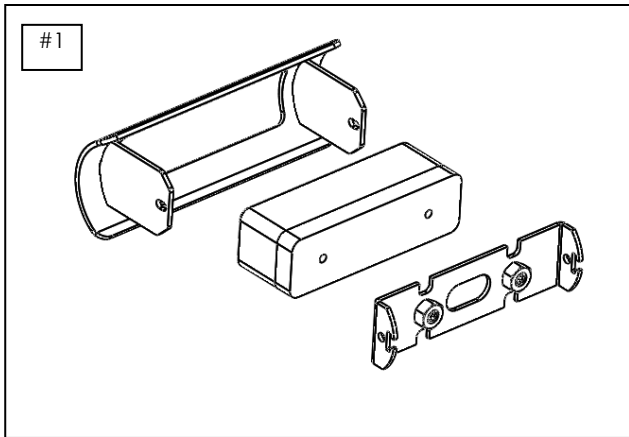

3. Repeat steps 1 & 2 for the other light. **Note: Make sure that all the lights have the same orientation.**
4. Refer to the installation and maintenance manual included with the lights to wire and configure the flash pattern. Note: Leave several feet of connector cable for connection to the light controller.
5. Feed the connector cable through the hole in the front bar channel and side panel until the hole in the push bumper center plate. Use the bolt guide attached to the side plate. **See image 4.**

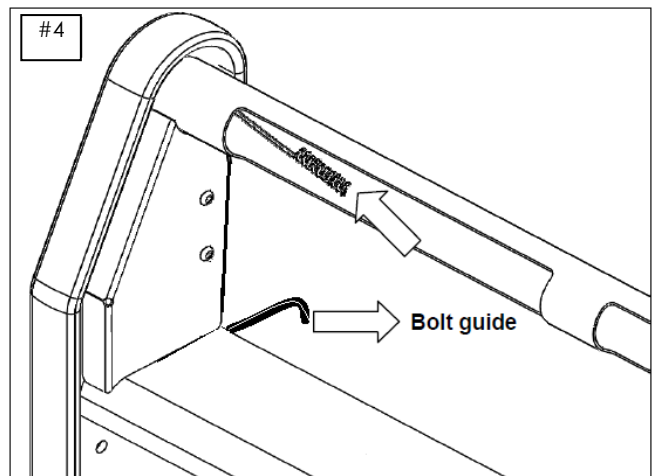

6. Place the lateral lights support in upright and attach using: (2) 1/4 x 2" Allen Head Bolt. Repeat for the other side. **See image 5.**

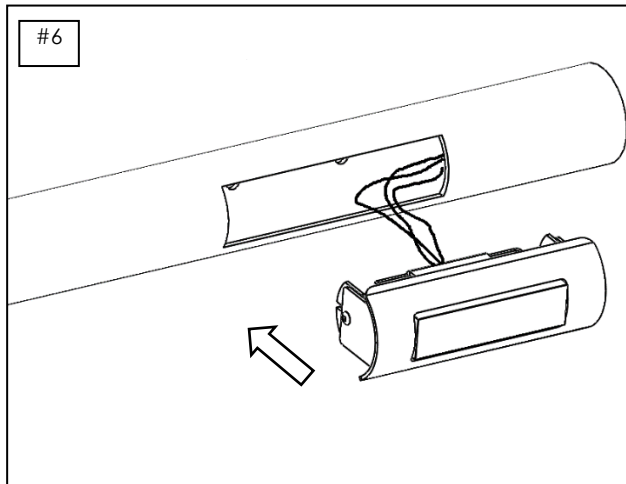
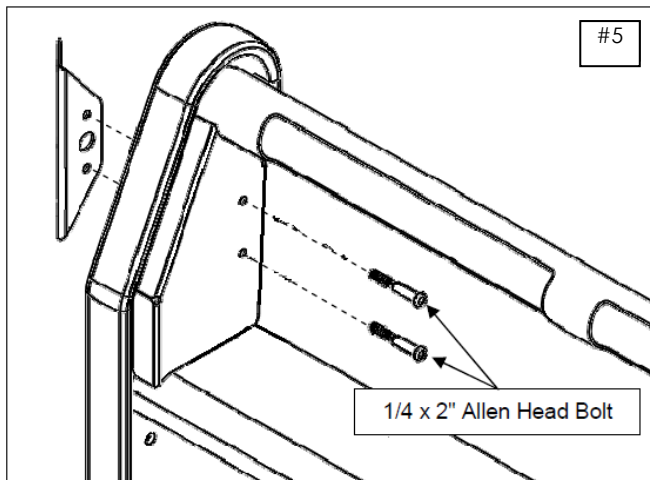

7. Secure the light bar assembly to the light bar tube using (2) 1/4" x 3/4" allen head bolt and (2) 1/4" lock washer. **See image 6 & 7.**

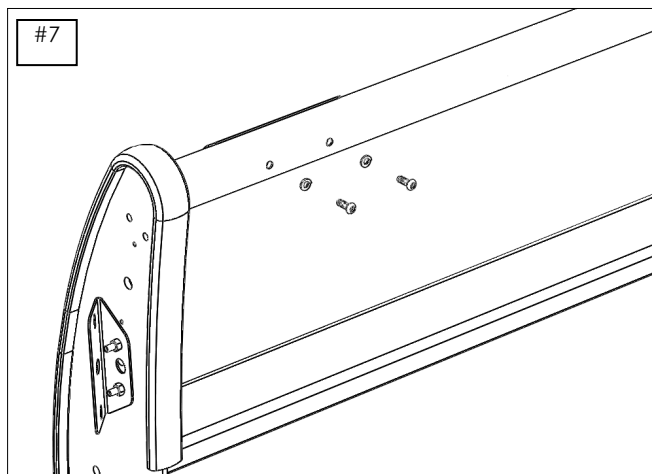

Front Bumper Fascia Removal

1. Open the hood, unsnap and remove the (12) plastic rivets (6) per side securing the bumper fascia support, and the (2) screws (1 per side) securing bumper fascia to the fender, (Photo 1).
2. From underside of the vehicle, remove the (6) screws (3 per side) securing the bottom of the bumper fascia to the plastic splash pan, (Photo 2).

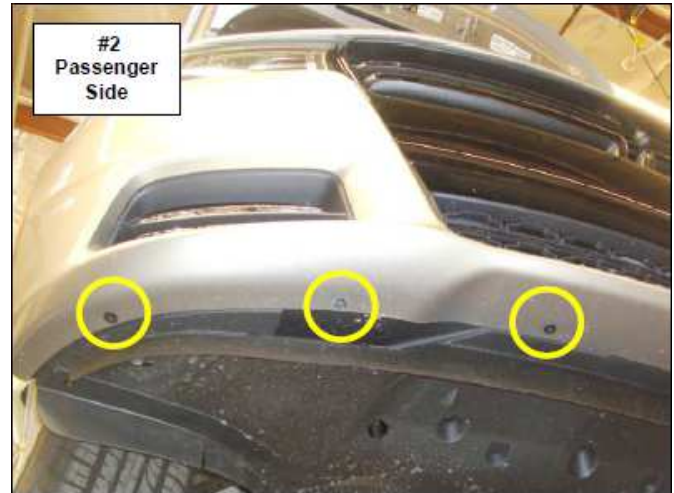
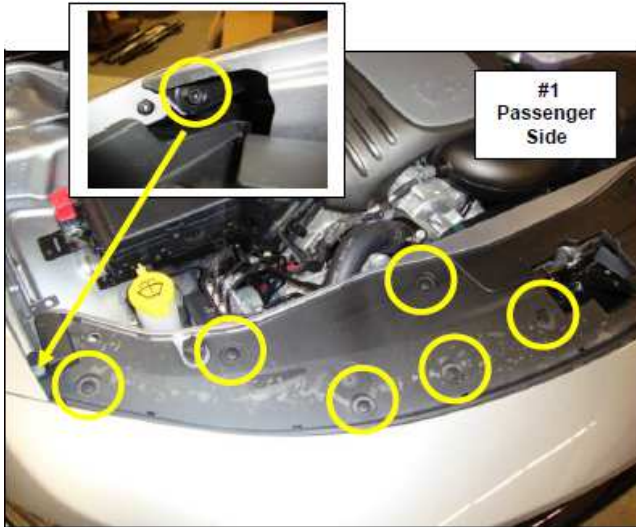

3. Remove the (3) screws securing the brake cooling duct to the fender well, (Photo 3).
4. Remove the (11) plastic rivets securing the front section of the fender well to the fender panel and bumper fascia, (Photo 4).

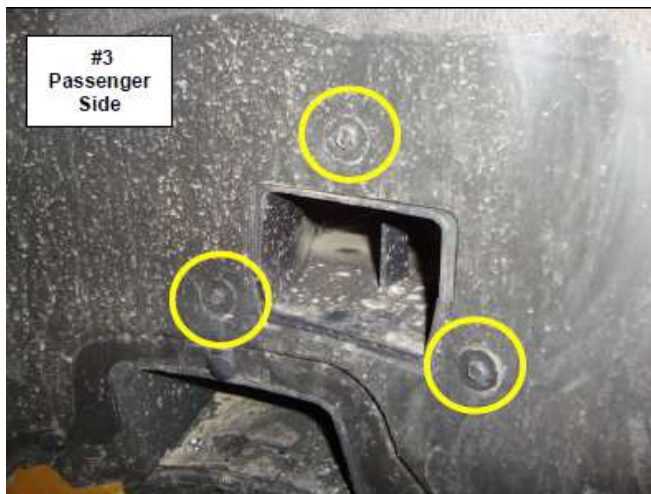

5. Pull back the front section of the fender well and remove the (2) bolts securing the bumper fascia to the fender. Disconnect (unplug) the side marker light wiring and If equipped disconnect the fog light, (Photo 5 & 6).

Repeat steps 3, 4 and 5 on the driver side of the vehicle.

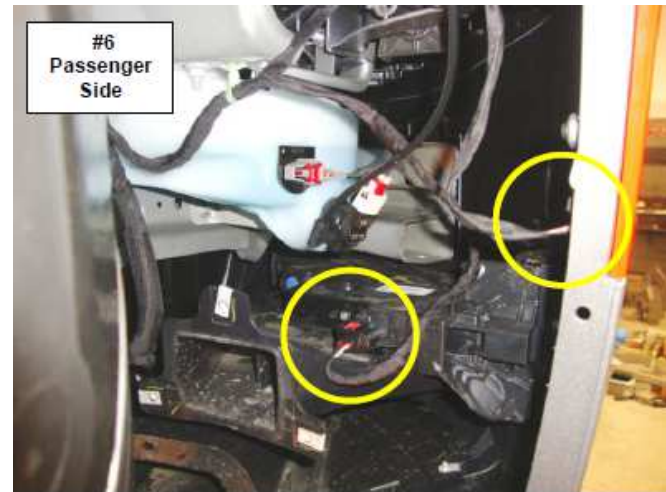
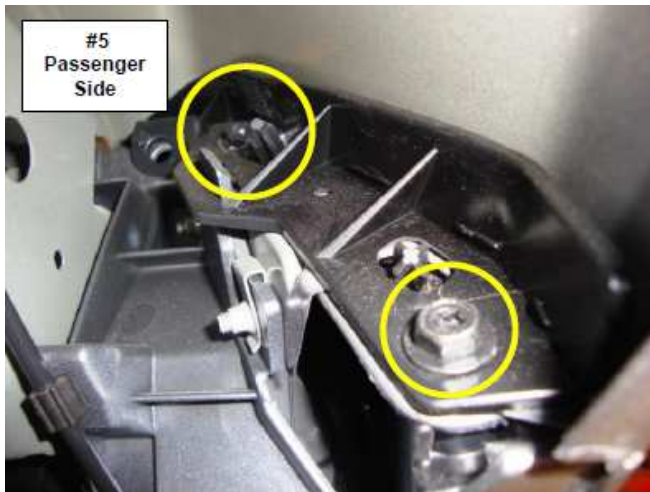

6. With assistance pull out on the sides of the fascia and forward to remove it from the vehicle.

7. Locate the holes in the bumper impact beam. Remove the bolts (2 per side) closest to the center of the vehicle, (Photo 7).

Push Bumper Installation

1. Assemble (2) of the 8mm hex bolts, (2) 5/16" lock washers, (2) 5/16" flat washers and (2) spacer tubes onto the flange of the passenger side bracket, (Photo 8).

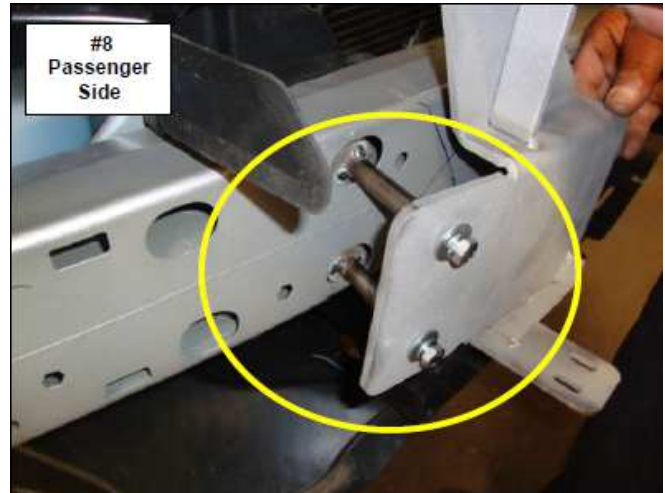

2. Attach the bracket to the impact beam. Position the flange of the bracket approximately 11 1/2" from the end of the impact beam and tighten the bolts, (Photo 9 & 10). Repeat steps 8 and 9 for the driver side bracket.

Note: To confirm the brackets are in the correct position, it is recommended to temporarily attach the push bumper to the brackets using the 3/8" bolts supplied

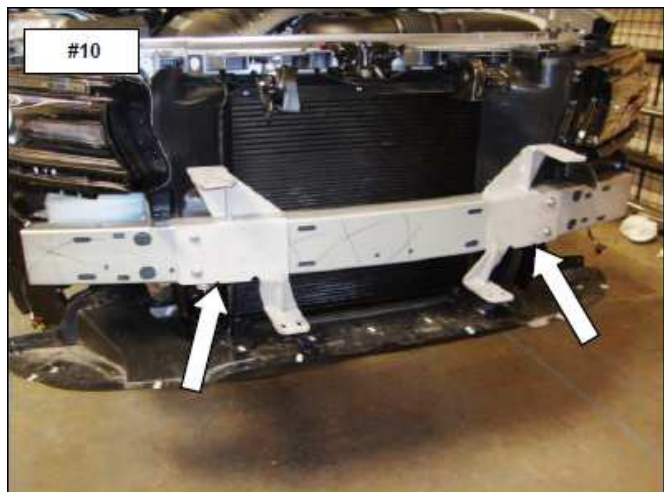

3. The bumper insulator must be notched (top and bottom) to properly fit around the brackets, (Photo 11 & 12). Remove the insulator from the bumper fascia. Position the insulator up to the bumper and mark the bracket locations. Notch the insulator and check fit by returning the insulator to the bumper until the proper fit is achieved. Re-install the bumper insulator in the bumper fascia.

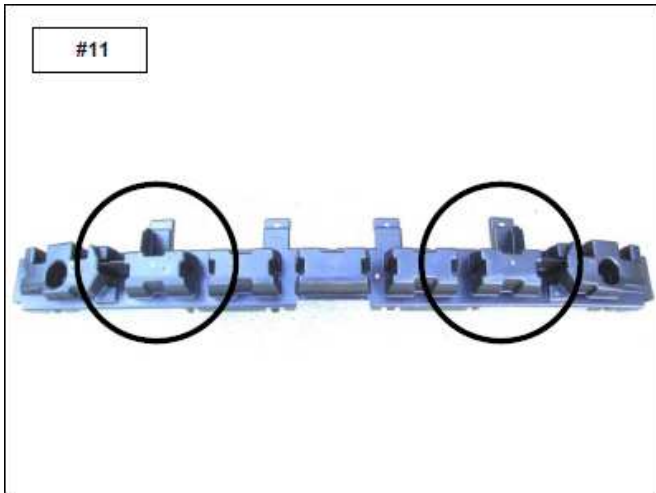

4. Remove the Dodge emblem from the upper grille, (Photo 13).

5. With assistance position the bumper fascia up to the vehicle, align the bumper fascia so the brackets protrude through the opening in the upper and lower grille and re-install the bumper fascia, (Photo 14).



6. Attach the push bumper to the brackets using the supplied 3/8" x 1 1/4" hex bolts, 3/8" flat washers, 3/8" lock washers and 3/8" hex nuts, (Photo 15).

7. Align the push bumper with the vehicle and tighten all nuts and bolts.

